

CABINET HARDWARE JIG

TOOL INSTRUCTIONS & HARDWARE INSTALL GUIDE





ABOUT US

True Position Tools was founded in 1996 by Tad Lostlen, a seasoned cabinet maker and installer determined to design an efficient cabinet hardware tool that would maximize productivity and eliminate error. This led to the creation of the best rated product of its kind, the Cabinet Hardware Jig.

As an American-owned family business for 25 years, we have proudly maintained best-in-class tools and continue to expand our product line with essential cabinet tools made in the USA.



CONTACT

PHONE 760-279-3033

EMAIL info@truepositiontools.com

WEB www.truepositiontools.com

BUSINESS HOURS

8:00 AM - 4:00 PM PST

MONDAY - FRIDAY

NO NEED TO RETURN!

Missing a part? Have questions, concerns or other issues? We are happy to help. We want you to be completely satisfied with your purchase. Please contact us directly and we will be happy to make it right.

TABLE OF CONTENTS

	Important Guidelines	Page 4
	Parts Diagram	Page 5
ORIGINAL	Knob on Drawer	Page 6
	Handle on Drawer	
	Knob on Door	Page 7
	Handle on Door	
	Drilling Hinge Plate Holes	Page 8
	Helpful Hints	
	Accessories	Page 9
	Shaker Drawer Spacers	
PRO	Rapid Center Extension	Page 10
	Large Handle on Door	Page 11
MAX	Large Handle on Drawer	Page 12
	Drilling Shelf Pin Holes	Page 13
	Upgrades & Products	Page 14
	Double Hole Drill Guide Set (16/32mm C-C Pattern)	Page 15

SAFETY GUIDELINES

- Read this manual fully before using the tool and operate this tool according to these instructions.
- Operating this tool before understanding safe and proper use could result in personal injury.
- Always wear certified safety equipment including eye, hearing, and respiratory protection.
- The drill bit is sharp. Handle with care. Avoid hand positions where a slip could cause contact with the bit.
- Do not operate this tool or any machinery while under the influence of drugs, alcohol, or medications.



WARNING: Drilling, sawing, sanding or machining wood products can expose you to wood dust, a substance known to the State of California to cause cancer. Avoid inhaling wood dust or use a dust mask or other safeguards for personal protection. For more information go to www.P65Warnings.ca.gov/wood.



SCAN FOR DIGITAL
INSTRUCTIONS

IMPORTANT

FOLLOW THESE GUIDELINES WHILE USING THIS TOOL

- Confirm hole spacing by screwing your hardware through bushings after tightening drill guides into position.
- Prior to use check all dimensions before drilling and confirm measurements by drilling on scrap wood.
- For high gloss or delicate finishes, use tape on tool or work piece to protect finish.
- Ensure thumb screws remain tight by checking after each time you drill into jig.
- Always use care when handling this tool, it is a precisely calibrated instrument. Take care to avoid accidental damage, do not drop or throw this against hard surfaces.
- Prior to use check jig for any imperfections or defects that may have occurred during prior usage, transport, or manufacturing that could result in inaccurate hardware placement or damage to workpiece. If you find any issues with your jig upon inspection contact us before use.

 Do not use pliers to tighten thumb screws, they should only be hand-tightened.

 Do not adjust any screws except for silver thumb screws, all other screws have been set and tightened to factory specifications to ensure accuracy.

CHOOSE YOUR CABINET HARDWARE JIG



ORIGINAL

- ✓ Fast, Accurate Hardware Installation in Seconds
- ✓ Any Door & Drawer + Hardware up to 12"

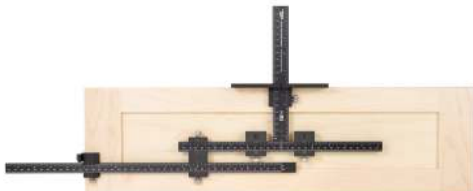

PRO

- ✓ The Original, *plus*:
- + Rapid Drawer Front Centering
- + Quick Repeatable Door Settings



MAX

- ✓ The Pro, *plus*:
- + Hardware up to 38" (965mm)
- + Shelf Pins with 32mm Spacing

Want to level up? Visit our website: www.TruePositionTools.com

PARTS DIAGRAM

INCLUDED PARTS VARY BY MODEL

MAX

PRO

ORIGINAL

INCLUDED IN ALL JIGS

-  Shaker Drawer Spacers
-  Hardware Spacing Pins
-  Magnetic Bushing Covers
-  5mm Drill Bit

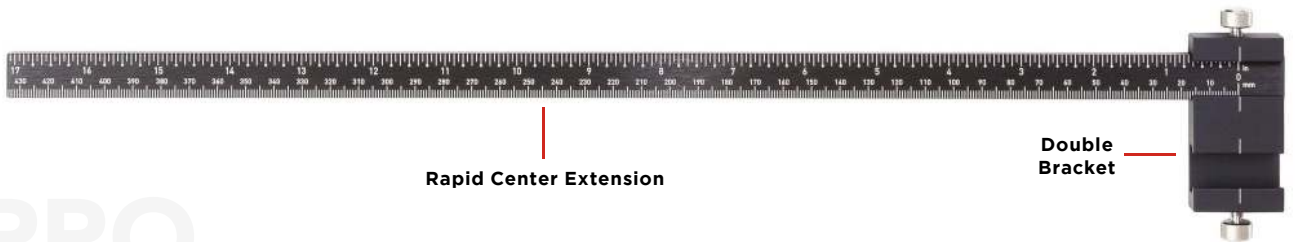
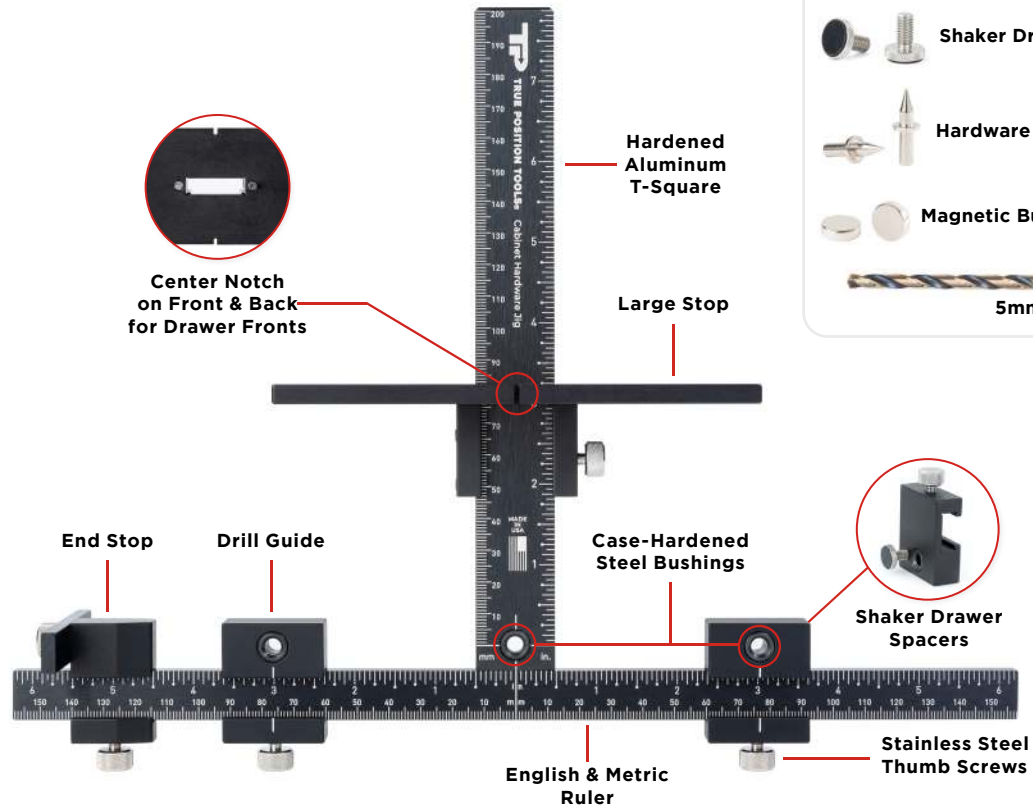

MAX

KNOB ON DRAWER



1 Place hardware to find position you like. (We are centering on width and height. Measure and mark if needed for non-centered applications.)



2 Measure drawer width to find center.



3 Mark center on top of drawer.

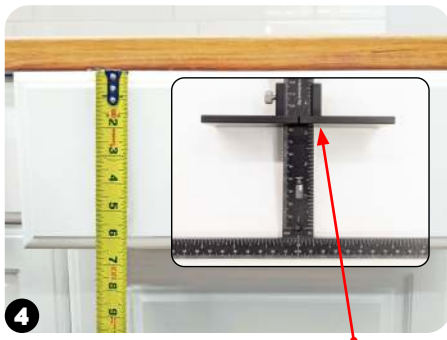

4 Measure height of drawer and set **Large Stop** at half of drawer height (if centering).



5 Line up notch on center of **Large Stop** with center mark at top of drawer then push tool flush against drawer face.



6 Hold securely and drill hole using fixed center drill bushing (**Large Stop** reversed for stability).

HANDLE ON DRAWER



1 Place hardware to find position you like. (We are centering on width and height. Measure and mark if needed for non-centered applications.)



2 Place Hardware Spacing Pins in bushings, keep Drill Guides loose. Set hardware onto spacing pins and press down until fully seated. Tighten thumb screws to set spacing. Ensure measurement is equal on both sides of the jig.



3 Measure drawer width to find center.



4 Use half of measurement from Step 3 to mark center on top of drawer.



5 Measure height of drawer front.

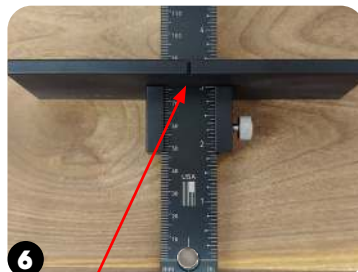

6 Set **Large Stop** to half of measurement from Step 5 (if centering).



7 Line up notch on **Large Stop** with mark from Step 4, then drill.



8 Install handle and repeat process for additional drawers.

ORIGINAL

KNOB ON DOOR



1 Place hardware (measure as needed) to find position you like; mark hole location



2 Measure from bottom of door to mark.

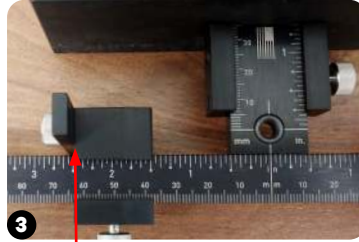

3 Set **End Stop** to measurement from Step 2 and tighten.



4 Measure from side of door to mark.

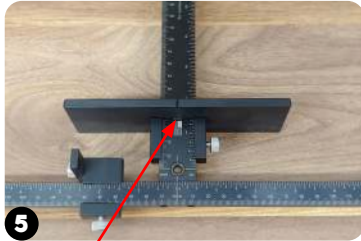

5 Set **Large Stop** to measurement from Step 4 and tighten.



6 Position tool with stops as shown and drill hole through drill bushing.



7 Flip tool to its reverse side, place on opposite door and repeat.



8 Install knob and repeat process for additional doors.

HANDLE ON DOOR



1 Place hardware (measure as needed) to find position you like; mark bottom hole location.



2 Measure from bottom of door to mark.



3 Set **End Stop** to measurement from Step 2 and tighten.



4 Measure from side of door to mark.

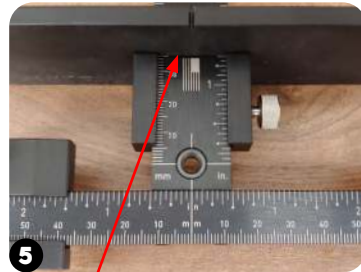

5 Set **Large Stop** to measurement from Step 4 and tighten.

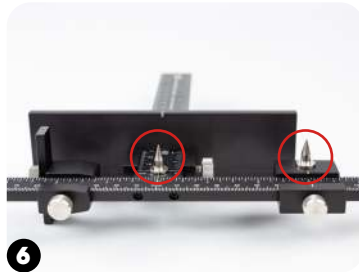

6 Place **Hardware Spacing Pins** in bushings, keep Drill Guide loose.



7 Set hardware onto spacing pins and press down until fully seated. Tighten thumb screws to set spacing.

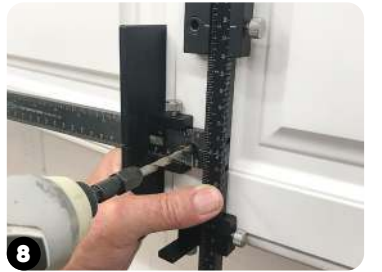

8 Hold securely and drill through fixed center bushing for bottom hole.



9 Drill through Drill Guide for top hole.



10 Flip tool to its reverse side, place on opposite door and repeat.



11 Install handle and repeat process for additional doors.

DRILLING HINGE PLATE HOLES

32MM SPACING ALLOWS FOR DRILLING CONCEALED HINGE MOUNTING PLATE HOLES



1 Mark center of hinge plate.

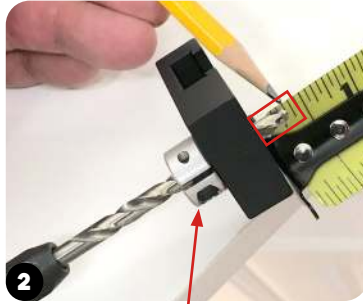

2 Set location of **Stop Collar** to **drill depth** using a **Drill Guide** as spacer and tighten with allen key.
(Drill depth varies depending on screw length and cabinet material thickness.)



3 Set **Large Stop** to **37mm** (industry standard).



4 Place **Large Stop** edge against cabinet face and use as a square to draw a line at mark from Step 1.



5 Place two **Drill Guides** side by side to achieve **32mm** spacing. Position tool with **Large Stop** and **T-square** firmly against cabinet surface. Adjust **Drill Guide** centers to previous mark and tighten. Drill first set of hinge plate holes.



6 Flip tool to bottom of cabinet, position tool with **Large Stop** and **T-Square** firmly against cabinet surface, and drill second set of holes.

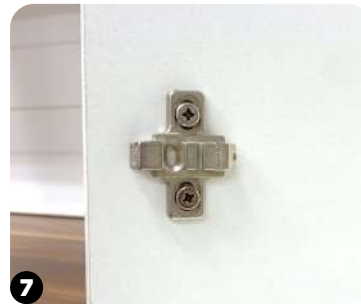

7 Install hinge mounting plate and repeat process for additional hinges.



8 Hinge mounting plate with hinge attached, ready for door installation.



HELPFUL HINTS

Using jig in the **Standard Large Stop** configuration provides **3 points** of support in most situations.

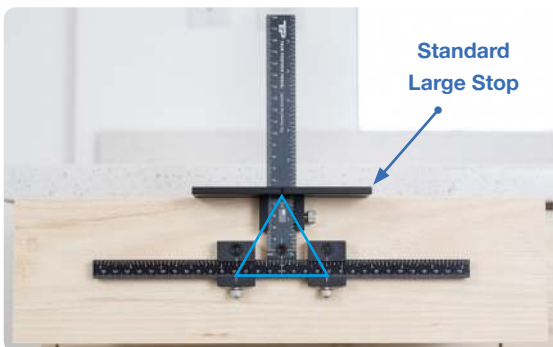

Standard Large Stop

Only **Reverse Large Stop** when additional clearance or stability is required.



See Examples:
Knob on Drawer - Page 6
Large Handle on Door - Page 11

Reversing **Large Stop** or **End Stop** can produce down to a **5/16"** (~8mm) minimum spacing from surface edges.

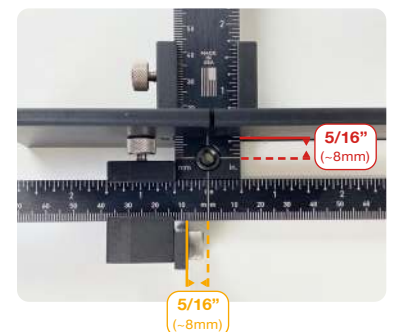

ACCESSORIES

SHAKER DRAWER SPACERS

PROVIDE STABILITY WHEN DRILLING RECESSED DRAWER FRONT PANELS



1

Remove Drill Guide and thread Shaker Drawer Spacer into reverse side.



2

Place Drill Guide on drawer front with Spacer on recessed portion. Adjust Spacer until it reaches the surface of the inset panel and the Drill Guide is level.



3

Return Drill Guides to appropriate measurements and drill holes.

MAGNETIC BUSHING COVERS

PREVENT DRILLING THROUGH INCORRECT HOLES BY COVERING UNUSED BUSHINGS



1

For example, when installing pulls on drawers, use **Magnetic Bushing Cover** to cover center hole.



2

Close-up of Magnet Bushing Cover placement.

HARDWARE SPACING PINS

FIND AND SET CABINET PULL SPACING QUICKLY AND ACCURATELY



1

For Doors: Place Hardware Spacing Pins in bushings, keep Drill Guide loose. Set hardware onto Spacing Pins and press down until fully seated. Tighten thumb screws to set spacing.

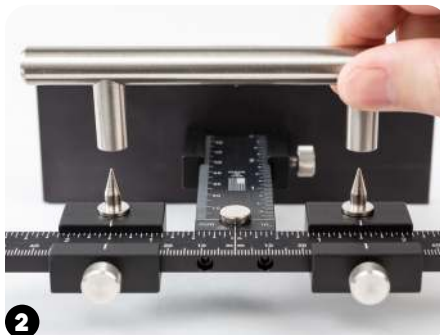

2

For Drawers: Place Hardware Spacing Pins in bushings, keep Drill Guides loose. Set hardware onto Spacing Pins and press down until fully seated. Tighten thumb screws to set spacing. Ensure measurement is equal on both sides of the jig.



RAPID CENTER EXTENSION ON DRAWER

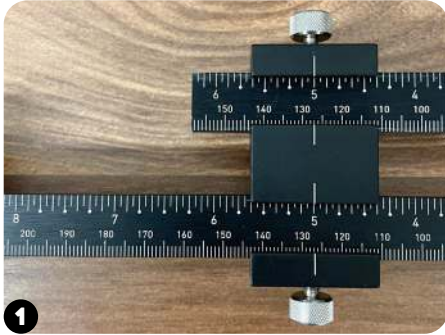

1 Connect Rapid Center Extension and Double Bracket to T-Square at 5" mark to extend length of ruler to 16".



2 Place hardware to find position you like. (We are centering on width and height. Measure and mark if needed for non-centered applications.)



3 Measure drawer width and divide in half to find the exact center.



4 Set the End Stop to half of the drawer width measurement from Step 3.

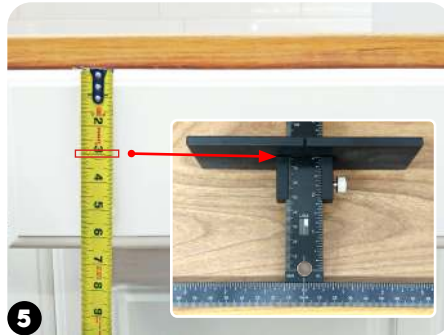

5 Measure height of drawer and set **Large Stop** to desired location and tighten thumb screws (half of measurement, if centering).



6A For Knobs: Drill through center bushing.

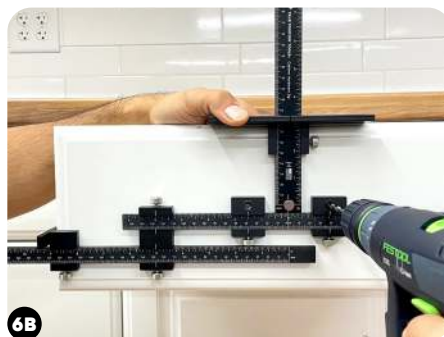

6B For Handles: Measure hardware and tighten Drill Guides to match hardware measurement, then drill (refer to Page 6, Handle on Drawer section if more information is needed).

FOR DRAWERS LARGER THAN 32"

- 1** Align 5" mark on T-Square with the 0" mark on the Rapid Center Extension, as shown in image.

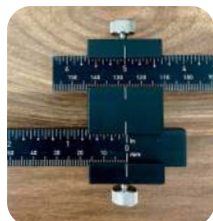

- 2** Measure drawer width, then DIVIDE in half and SUBTRACT 5"

EXAMPLE

For 40" Drawer Front
 $20''$ (half of 40'') - 5'' = 15''

End Stop is then placed on 15" mark



PRO TIP



If handle pattern interferes with Double Bracket, align Bracket and Rapid Center Extension to number on T-Square that doesn't interfere (aligned at 2" in above image)

PRO TIP



LARGE HANDLE ON DOOR



1 Place hardware (measure as needed) to find position you like; mark bottom hole location with pencil.



2 Measure from bottom of door to mark.



3 Slide the Long Pull Extensions all the way onto the T-Square, and tighten all four thumb screws.

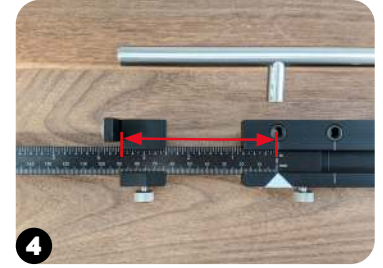

4 Attach Rapid Center Extension and set at index mark for bottom hole. Set End Stop to measurement from Step 2.



5 Measure from side of door to mark.

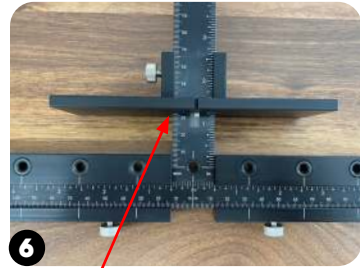

6 Set **Large Stop** to measurement from Step 5 and tighten thumb screws. (If needed, reverse Large Stop for additional clearance).

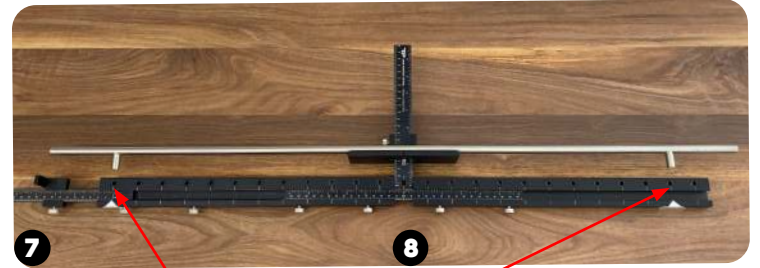

7 Match the **bottom hole** on hardware to bottom hole on Long Pull Extension and mark with tape.

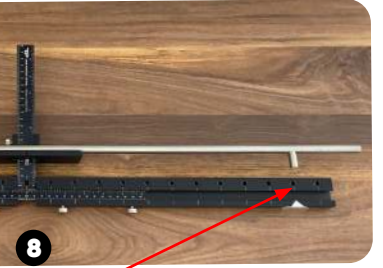

8 Match **top hole** on hardware to matching hole on Long Pull Extension; mark hole with tape.



9 Hold both stops firmly against door and drill bottom hole.



10 Drill top hole.



11 Flip tool to its reverse side, place on opposite door and repeat drilling.



The majority of large pulls fit perfectly into our Long Pull Extension hole pattern, as large pulls typically come in 32mm increments — the same increments as our hole pattern!

LARGE HANDLE ON DRAWER

FOR HANDLES LONGER THAN 12" (C-C)



1 Place hardware to find position you like. (We are centering on width and height. Measure and mark if needed for non-centered applications).

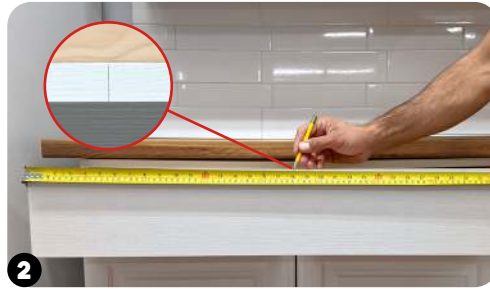

2 Measure drawer width and divide in half to find the exact center.

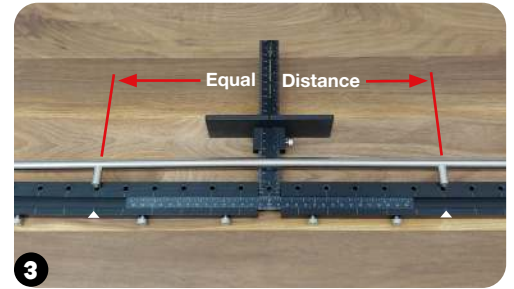

3 Place hardware on Long Pull Extensions and mark holes to be drilled with tape (if needed, adjust Extensions equally left and right until holes align).

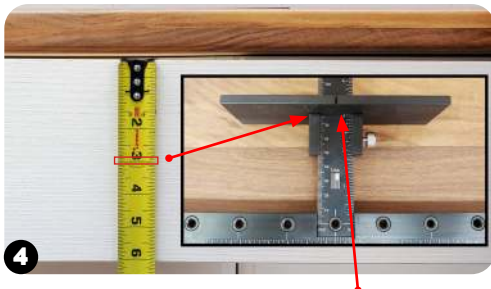

4 Measure height of drawer and set Large Stop to desired location (half of measurement, if centering).



5 Attach the Rapid Center Extension with End Stop to the Long Pull Extension. Place jig on marked center and slide the End Stop to edge of drawer and tighten.



6 Hold both stops firmly against top and side of drawer. Drill through marked holes and install hardware.

ADDITIONAL OPTIONS FOR DIFFERENT HANDLE & DRAWER SIZE VARIATIONS



1 Line up center of one end of hardware with edge of drawer front, and measure from opposite end of drawer to center of other hardware hole, to find total length of drawer without hardware.

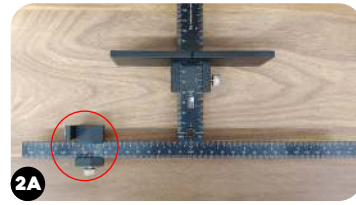

2A Set End Stop at half the measurement from Step 1. **2A** If half your measurement is 6" or under, tighten the End Stop at your number directly on T-Square.

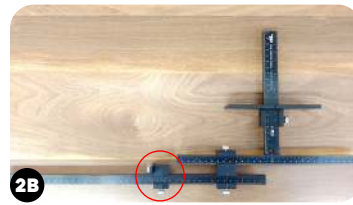

2B If half your measurement is over 6", attach the Rapid Center Extension and tighten the End Stop at your number on the Rapid Center Extension.

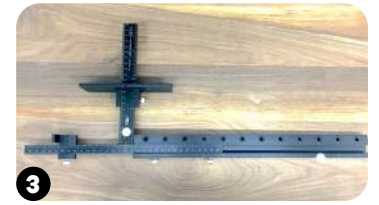

3 Attach one Long Pull Extension to the right side, and use the hole in the center of your T-Square as the first hole you will drill through.



4 Confirm hole spacing using your hardware. Adjust Long Pull Extension as needed, then tighten thumb screws when hardware aligns with holes on Long Pull Extension.

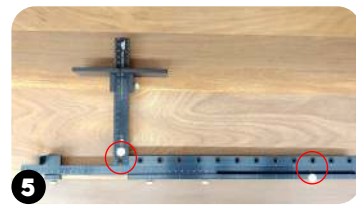

5 Mark selected holes with tape to avoid drilling through incorrect holes.



6 Measure height of drawer and set Large Stop to desired location (half of measurement, if centering).



7 Hold both stops firmly against top and side of drawer. Drill through marked holes and install hardware.

MAX

DRILLING SHELF PIN HOLES

QUICKLY DRILL HOLES FOR 5MM SHELF PINS WITH 32MM SPACING

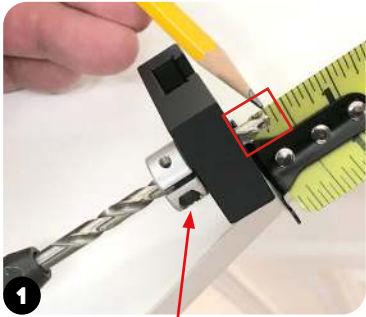

1 Set location of **Stop Collar to drill depth** using a Drill Guide as spacer and **tighten with allen key.**
(Drill depth varies depending on screw length and cabinet material thickness.)

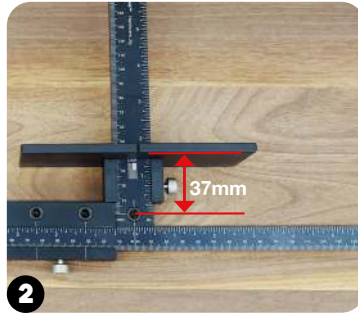

2 Mount Long Pull & Shelf Pin Extension firmly against T-Square. When Large Stop touches Extension, the industry standard for shelf pin offset of **37mm** is achieved. Depth can be adjusted to suite your project.



3 Measure and mark desired location of center hole to be drilled (we are drilling in sets of three).



4 Slide Rapid Center Extension, choose any drill bushing and align it with mark in cabinet from Step 1, tighten thumb screws.

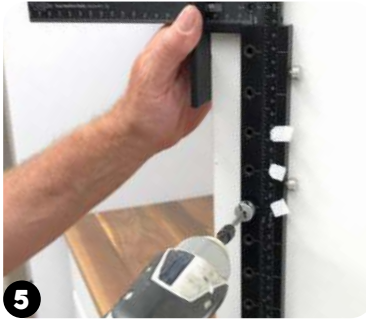

5 Mark your holes with tape for reference, and drill first set of shelf pin holes.



6 Remove Large Stop and press thumb screws against back panel then drill.

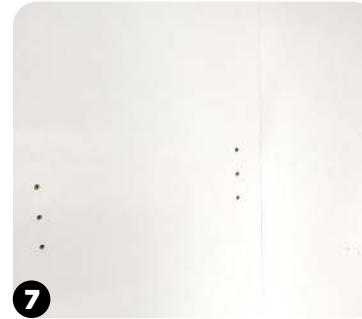

7 Perfectly spaced at 32mm every time.

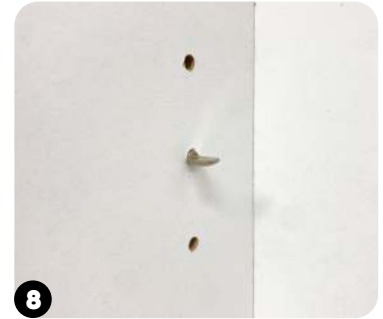

8 Install 5mm shelf pins and repeat as needed.

TAKE YOUR JIG TO THE NEXT LEVEL

Find these products and more at www.TruePositionTools.com



UPGRADE TO MAX

LONG PULL & RAPID CENTER EXTENSION SET

If you bought the Original CHJ and need to install long handles or add shelf pins on site, the Long Pull & Rapid Center Extension Set allows you to do just that.

TP-CHJ-LPRC



UPGRADE TO PRO

RAPID CENTER EXTENSION

Speed up hardware installation by using the Rapid Center Extension, eliminating the need to center your jig on each drawer. Attach for quicker centering on wide drawer fronts and tall doors. Allows for adjustable starting point for line boring in assembled cabinets.

TP-CHJ-RC



CABINET LIGHTING

CABINET LIGHT JIG

Simplify cabinet lighting with our revolutionary Cabinet Light Jig.

TP-CLJ



The Cabinet Light Jig installs light wires within the structural panels of the cabinet, eliminating the need for a light rail or double bottom.



ADD-ON

DOUBLE HOLE DRILL GUIDE SET (16mm & 32mm Pattern)

For installation of 16mm & 32mm Center-to-Center pulls and knobs on cabinet doors and drawer fronts. These Drill Guides attach to **ORIGINAL** (TP-CHJ), **PRO** (TP-CHJ-PRO), and **MAX** (TP-CHJ-MAX) Cabinet Hardware Jigs.

TP-CHJ-DHG



Double Hole Drill Guide Instructions: Installing 16mm/32mm C-C Hardware

DRAWER INSTALL

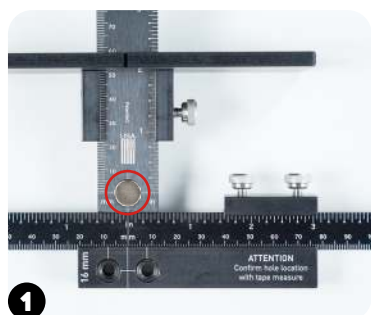

1

Attach and center Double Hole Drill Guide attachment to center line on T-Square. Cover unused bushing with **Magnet**.

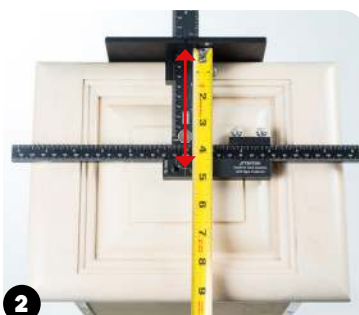

2

Measure height of drawer front, adjust Large Stop to desired height by referencing the center line on Drill Guide.

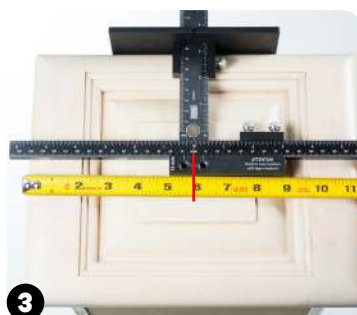

3

Center T-Square on drawer front referencing center line on Drill Guide.



4

Secure jig and drill. Install hardware.

DOOR INSTALL

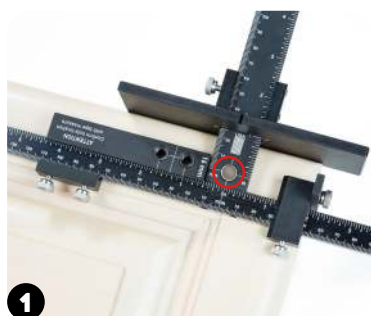

1

Attach Double Hole Drill Guide attachment to T-Square with the End Stop on the opposite end. Cover unused bushing with **Magnet**.

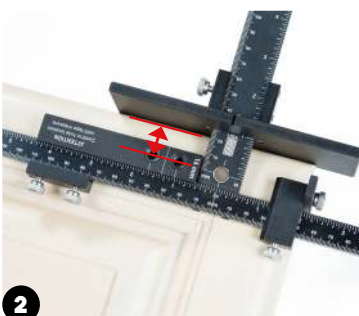

2

Adjust Large Stop to desired distance from edge of door to the center line on Drill Guide attachment.



3

Adjust End Stop to desired distance from hardware holes.



4

Secure jig and drill. For paired doors, simply flip the jig over to quickly repeat settings and drill. Install hardware.

TAG US IN YOUR PROJECTS



@TRUEPOSITIONTOOLS



MADE IN USA SINCE 1996

PATENT PENDING

Except as otherwise noted, all marks used are trademarks and/or registered trademarks of True Position Tools and its affiliates in the U.S. and elsewhere. ® = registered in the U.S. Patent and Trademark Office © 2022 True Position Tools. All rights reserved.